



FIRESTOP CENTRE

Authorised New Zealand Distributor
Ph (09) 483 4000 www.firestopcentre.co.nz

AGNI-Sleeve in 100mm CLT Wall PVC-U Pipe (32mm - 80mm) FRR -/60/60

System ID# FC844

Step-by-step installation instructions:

1. Ensure the aperture is free from dust and debris.
2. Remove the base fabric of AGNI-Sleeve before installation.
3. Wrap 120mm wide AGNI-Sleeve around the service, where 10mm of AGNI-Sleeve extends beyond the CLT wall on both sides.
4. Seal all joints with a nominal 5mm bead of AGNI-Seal on both sides of the wall.

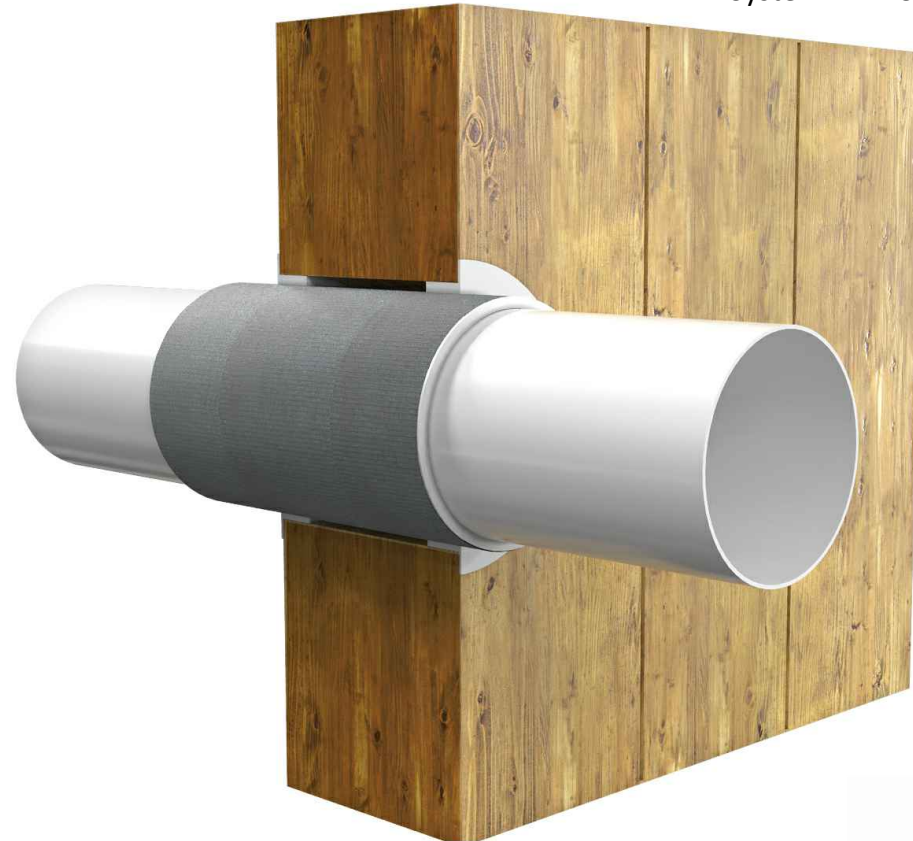

Technical Information

Substrate	Min. 100m CLT wall
Service range	DN 32mm-80mm PVC-U pipe
Annular gap	9mm - 10.5mm
AGNI-Products	AGNI-Seal, AGNI-Sleeve
Protection installation	Both sides of the wall

Compliance Information

Standards	AS1530.4-2014, AS4072.1-2005
FRR/FRL	-/60/60
Reference	RIRF24086 (AP-094)



Agnitek
FIRE RATED TECHNOLOGY

8 Clare St Bayswater
VIC 3153, AUSTRALIA
www.agnitek.com.au

Disclaimer
Agnitek reserves the right to modify product specifications without prior notice due to its ongoing research, development & certification programme. The information in this document is provided in good faith and is intended for guidance purposes only. Any accompanying drawings are solely for illustrative purposes. Since Agnitek cannot oversee installation methods or ensure site conditions, no warranties, expressed or implied, are intended regarding the products' actual performance. We do not accept liability for any loss, damage, or injury from using this information. Please take a look at the test reports displayed on a relevant AGNI-System webpage for all compliance specifics.

Date | 30.08.2024



FIRESTOP CENTRE

Authorised New Zealand Distributor
Ph (09) 483 4000 www.firestopcentre.co.nz

AGNI-Sleeve in 100mm CLT Wall PVC-U Pipe (32mm - 80mm) FRR -/60/60

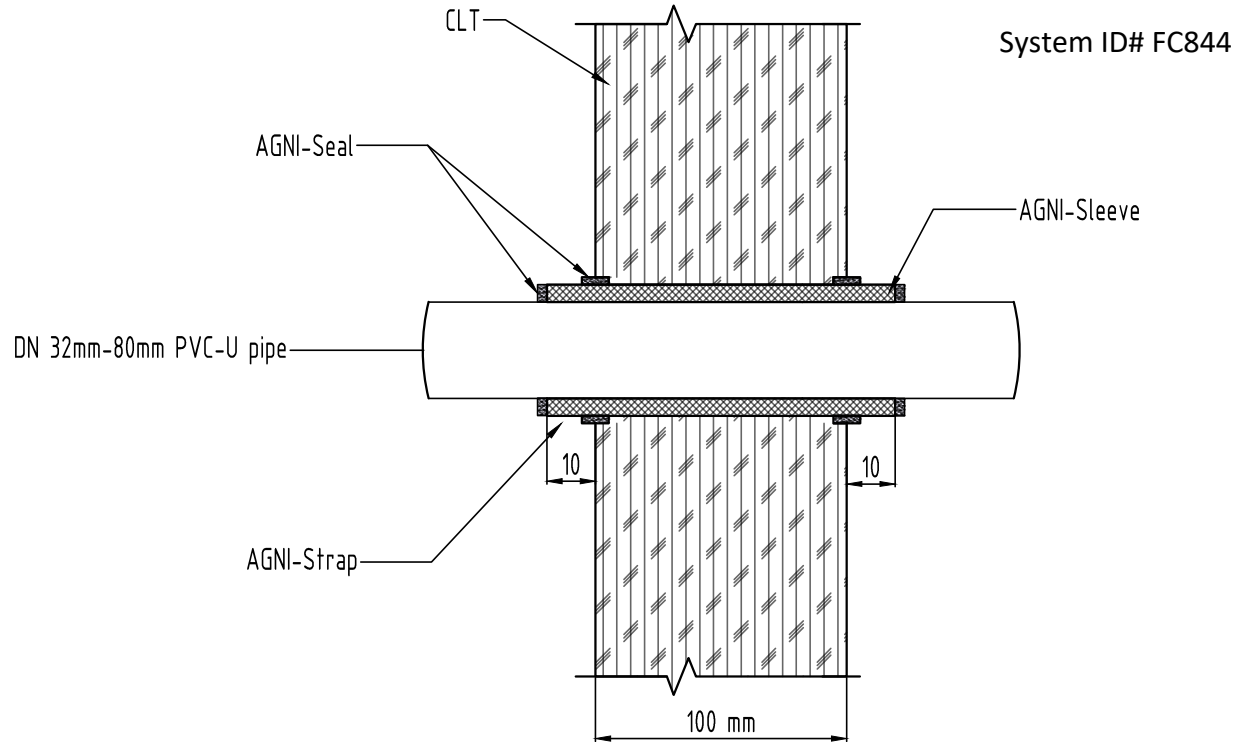

Technical Information

Substrate	Min. 100m CLT wall
Service range	DN 32mm-80mm PVC-U pipe
Annular gap	9mm - 10.5mm
AGNI-Products	AGNI-Seal, AGNI-Sleeve
Protection installation	Both sides of the wall

Compliance Information

Standards	AS1530.4-2014, AS4072.1-2005
FRR/FRL	-/60/60
Reference	PF24086



Agnitek
FIRE RATED TECHNOLOGY

8 Clare St Bayswater
VIC 3153, AUSTRALIA
www.agnitek.com.au

Disclaimer
Agnitek reserves the right to modify product specifications without prior notice due to its ongoing research, development & certification programme. The information in this document is provided in good faith and is intended for guidance purposes only. Any accompanying drawings are solely for illustrative purposes. Since Agnitek cannot oversee installation methods or ensure site conditions, no warranties, expressed or implied, are intended regarding the products' actual performance. We do not accept liability for any loss, damage, or injury from using this information. Please take a look at the test reports displayed on a relevant AGNI-System webpage for all compliance specifics.

Date | 30.08.2024